

# FOOT-RING ASSEMBLY MANUAL

## \* Assembly Instructions:

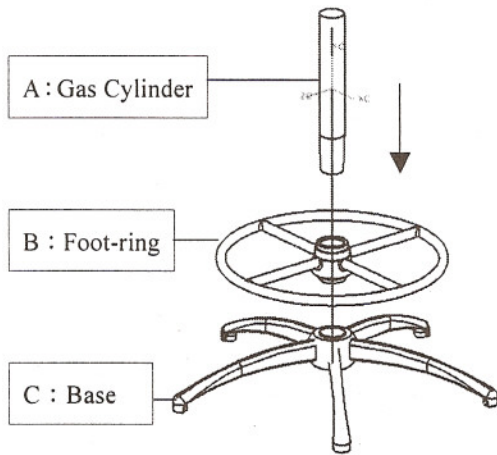

Fig. 1

1. Before assembling, check that the foot-ring is at the top of the central hub's thread by turning the foot-ring anti-clockwise. This ensures that the mechanism is released and able to fit over the gas cylinder.
2. Assembly - Position the foot-ring on the gas cylinder at the desired height. Hold the bottom of the plastic hub with one hand and the outer ring with the other. Turn the outer ring clockwise to tighten the foot-ring. (Refer to Fig. 4)

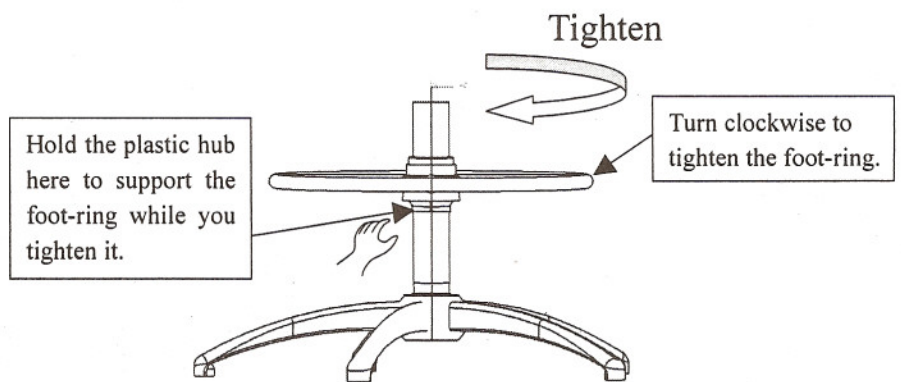

Fig 4.

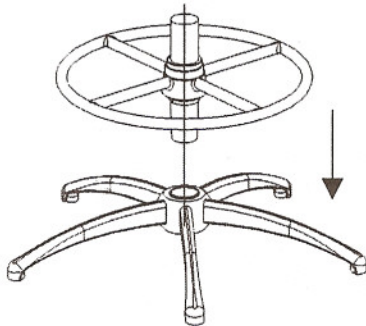

Fig. 2

3. Height Adjustment - Hold the base with one hand and turn the foot-ring anti-clockwise approx. a  $\frac{1}{4}$  rotation just to loosen. Hold the bottom of the plastic hub with one hand and the outer ring with the other and continue to turn anti-clockwise until the foot-ring is released and can move freely up and down the gas cylinder. (Refer to Fig. 5)

Adjust the height as required and then tighten again. (Refer to Fig. 4)

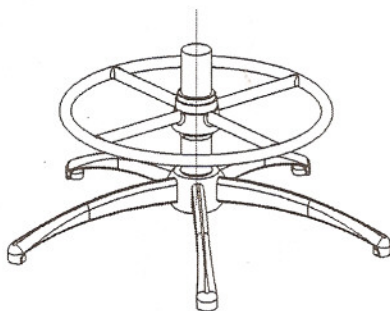

Fig. 3

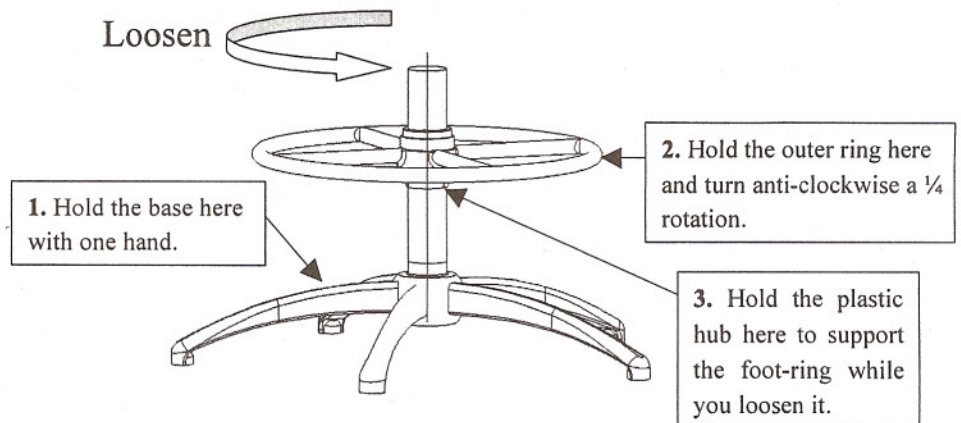

Fig. 5